

# Tempo

## Sidekick<sup>®</sup> 7B and T&N

### Training Course

Revision 1.03



**7B Model**



**T&N Model**



This manual is for training purposes only.

## **PREAMBLE**

*“Never could a highly trained and experienced technician place more emphasis on how paramount a thorough understanding of the following principles and analytical procedures are to “Finding a better way” to trouble shoot outside plant and equipment...”*

# Table of Contents

<b>A BRIEF HISTORY OF TEMPO RESEARCH CORPORATION .....</b>	<b>V</b>
THE EVOLUTION OF THE SIDEKICK .....	V
ORIGIN OF THE NAME .....	V
<b>MASTERING THE FUNDAMENTALS.....</b>	<b>1</b>
BASIC ELECTRONICS.....	1
<i>Copper Wire</i> .....	1
<i>Voltage</i> .....	1
<i>Current</i> .....	2
<i>Resistance</i> .....	2
<i>Ohms Law</i> .....	2
<i>Capacitance</i> .....	2
<i>Capacitive Reactance</i> .....	3
<i>Inductance</i> .....	3
<i>Inductive Reactance</i> .....	3
<i>Power Formulas</i> .....	4
CONNECTING TO OUTSIDE PLANT.....	4
FAULT TYPES .....	4
<i>Opens</i> .....	5
<i>Shorts</i> .....	5
<i>Grounds</i> .....	5
<i>Resistance Faults</i> .....	5
<i>Noise</i> .....	5
<i>Line Imbalance</i> .....	5
<i>Crosses</i> .....	6
<i>Splits</i> .....	6
<i>Power Influence</i> .....	6
<i>Induction</i> .....	6
<i>Circuit Loss</i> .....	6
<i>Loop Current</i> .....	6
<b>SIDEKICK 7B .....</b>	<b>7</b>
<i>General Description</i> .....	7
<i>Features</i> .....	7
<i>Benefits</i> .....	8
Front Panel Controls .....	8
AC Volts Test .....	9
DC Volts Test .....	9
<b>QUIZ 1.....</b>	<b>10</b>
<i>Stress Test</i> .....	12
<i>Fault Types Identified</i> .....	12
<i>Proper Ground</i> .....	12
<i>Procedure</i> .....	13
<i>Identifying a Pair or Cross Conductor</i> .....	13
<i>Bridged Stressed Noise Readings</i> .....	15
<i>Trouble Isolation</i> .....	15
<i>Stress Test Effectiveness</i> .....	16
<i>Questionable Cables</i> .....	16
<i>Equipment Balance</i> .....	16
<i>Testing DSSC, DAML, OR UDC Pair Gain Line</i> .....	17
<i>Troubleshooting Tips</i> .....	17

<b>QUIZ 2.....</b>	<b>19</b>
Leakage Test.....	21
Resistance Test.....	22
<i>Resistance/Conductor Length (Approximate)</i> .....	22
Capacitive Kick.....	23
<i>Kickmeter</i> .....	23
<i>To Kick a Pair</i> .....	23
<i>Capacitance/Conductor Length (Approximate)</i> .....	23
<b>QUIZ 3.....</b>	<b>25</b>
<b>EXAM 1.....</b>	<b>27</b>
<b>SIDEKICK T&amp;N.....</b>	<b>30</b>
<i>Features</i> .....	30
<i>Benefits</i> .....	30
Front Panel Controls.....	30
Coil Detect Test.....	32
Loop Current Test.....	33
Power Influence Test.....	34
Circuit Noise Test.....	34
Circuit Loss Test.....	35
<b>QUIZ 4.....</b>	<b>37</b>
<b>EXAM 2.....</b>	<b>39</b>
<b>QUIZ &amp; EXAM ANSWERS.....</b>	<b>41</b>
<b>TROUBLE SHOOTING INSIDE WIRING.....</b>	<b>42</b>
<i>Testing for Good Ground</i> .....	42
<i>Stressing the pair</i> .....	42
<i>Resistance Testing – Fault Isolation</i> .....	42
<i>Resistance Testing – Toning the Fault</i> .....	43
<i>Capacitance Testing – Kicking the Pair</i> .....	43
<b>CLEANING AND MAINTENANCE.....</b>	<b>44</b>
<i>Ground Clip Replacement</i> .....	44
<i>Test Lead Replacement</i> .....	45
<i>Battery Replacement</i> .....	45
<b>FREQUENTLY ASKED QUESTIONS.....</b>	<b>46</b>
<b>GLOSSARY.....</b>	<b>49</b>

## A Brief History of Tempo Research Corporation

In August 1984, a small San Diego based company, Tempo Research Corporation, began designing, developing, manufacturing, and marketing copper cable fault locators for the telecommunications industry. As time progressed, it became evident that fiber optics would replace copper wire. Despite the growing talk about fiber optics, Tempo believed that copper was not going to go away as quickly as some people thought and decided to stay focused on the copper market where Tempo had the most expertise. Dedicated to “Finding a better way”, research lead to the development of a reliable hand held test instrument that is used by every major telephone company in the United States today to troubleshoot twisted pair applications. It has also become the technicians’ test set of choice worldwide – the Sidekick<sup>®</sup>.

## The Evolution of the Sidekick

### Origin of the Name

The Sidekick’s name originated from its characteristics and features. The word *Side* came from the ability to carry or hook the test instrument on the side of a technician’s tool belt. The word *Kick* was inherited from a common telephony practice whereby the length of a wire in a pair, or a pair of wires, could be determined from their capacitive discharge. The practice of “Kicking the pair” was greatly enhanced by two of the Sidekick’s most powerful troubleshooting features, the “Leakage Test” and the patented “Stress Test”.

### The Original Sidekick 7A

In January 1991, Tempo Research Corporation released the first Sidekick 7A. It was a compact Volt Ohm Meter designed specifically for telephone companies, but it had one additional feature called a “Noise Test” that would catapult this unknown instrument into a valuable telecommunications industry product. The Noise Test utilized an entirely new patented method of testing the voice grade of a circuit. It induced a 90 dBmC signal on top of 135 Volts DC into a copper wire pair instead of using methods that depended on the presence of ambient noise. The sum affect was to stress a telephone cable pair to the limit and see if voice grade quality could be sustained without the presence of “Noise” on the line. Other test equipment at this time performed passive testing for noise and balance which didn’t always reveal faults. This new test allowed technicians to measure a telephone pair’s ability to carry a voice signal without noise interference under worst-case noise conditions. Even minor fault readings were detectable on pairs, otherwise, thought to be good. One hundred Sidekicks were produced and sold before the revised Sidekick 7A was manufactured later that year.



## The Revised Sidekick 7A

A Leakage test was added to the original Sidekick and the patented Noise Test was renamed the Line Test. Color coding was also added to the meter scale and the toggle switches which replaced the original push buttons. The Leakage test continued to use DC



wires in a pair or a wire and ground. With this higher voltage and the technician's ability to reverse the polarity, technicians could "Punch through" the galvanic corrosion that often built up on unused pairs. This corrosion which acts like a false insulator, often masks a pair's fault that returns after only a few applications of ring voltage.

Word began to spread that technicians using the Sidekick were doing a better job. There were fewer problems and fewer repeat trouble reports when a Sidekick was used.

After approximately forty-five hundred of these were produced, the next generation of Sidekicks began to arrive – the Sidekick 7B.

## The Sidekick 7B

In 1993, the Sidekick received a complete face lift and some ergonomic improvements based on recommendations from the field. The meter was enlarged and moved to the top of the case. The case was redesigned to round out the "Boxy look" and the "Line Test" was renamed the now famous "Stress Test." Industry praise bolstered sales that had steadily climbed; further embedding the Sidekick in the telecommunications marketplace.



## The Tempo 7B

In 1995, the Tempo 7B became the first Sidekick to use the "Big Head" design. The case was redesigned, not only to accommodate an even larger meter face, but to also provide expansion for additional features. AC voltage testing was added and the switch positions were relocated to take advantage of this new design. The old push button style switches were put back in service. Unfortunately, the field technicians preferred toggle switches. Only four thousand were sold before being replaced by the Sidekick 7B "Big Head".





## The Sidekick 7B “Big Head”

The Sidekick 7B “Big Head” made its appearance in 1996, and because of their popularity, toggle switches became the standard. Currently used throughout the telephone industry, the Sidekick 7B embraces unparalleled competition as the technicians “Test set of choice”. It is used by every major telecommunication company in the United States as well as numerous countries around the globe.

## The Sidekick T&N

In 1998, the Sidekick T&N was introduced with five Transmission and Noise tests to keep up with the industry’s demand for more comprehensive testing. Load Coil Detection, Loop Current, Power Influence, Circuit Noise, and Circuit Loss Testing were added to the current Sidekick test functions. With enhanced color coding for improved meter readability and test function coordination, the T&N has become so practical and efficient that the need to rely on supplemental test equipment is now rare. It received its acceptance at every Regional Bell Operational Center (RBOC) in 1998 and has become even more popular than the Sidekick 7B.



## The VIP Sidekick

In the early part of 2000, the Sidekick evolved into the Virtual Instrument Package (VIP Sidekick). A major communications company requested a unique conceptual form of the Sidekick for their new Intelligent Field Device (IFD). The IFD is a Panasonic® Model CF-27 Toughbook® computer with both land-line and wireless modems for dispatch and close-out. The VIP Sidekick module was developed to meet specific criteria and is leading the way for the development of future VIP modules for multi-purpose testing. When the module is inserted in the Toughbook, technicians have Pentium PC power driving on-screen instrumentation with digital testing accuracy. In addition to having all the features from previous Sidekick models, the VIP also has a Digital Open Meter, Trace and Loss Tones, Caller ID, a Resistance/Distance Calculator, a Modem Line Tester; and an Autotest which is an advanced automated preprogrammed test sequence that automatically displays Pass/Fail test results based on testing criteria configured by the technician, and a detailed on-line user training and help system.



# Mastering The Fundamentals

## BASIC ELECTRONICS

This section provides an overview of basic electronics and the theory associated with outside plant telephone circuitry. Those not familiar with electronics should review this material for a basic understanding of how the various electrical characteristics in a circuit interact. It is important to know that each twisted pair of copper wires in a telephone cable forms a circuit. Topics covered include copper wire, resistance, current, voltage, Ohm's law, capacitance, capacitive reactance, inductance, inductive reactance, power formulas, and the factors that affect these characteristics.

### Copper Wire

Copper wire is the most commonly used material as a conductor in electrical and telephone circuits due to its excellent electrical properties. Copper wire is available in many gauges (diameters). The lower the gauge number, the larger the diameter of the wire. For example, a 10 gauge wire is larger in diameter than a 19 gauge wire. As the gauge increases, the diameter decreases; and the resistive and capacitive characteristics of the wire to electrical flow increase. Temperature, humidity and other factors affect the properties of copper wire.

Even though smaller wire diameters offer more resistance, it is the physical concerns of size and weight of larger wires and cables that lead to the use of small wires. In a typical environment of 68° Fahrenheit and normal humidity, the length of different gauge wires when reading 1 ohm resistance on a meter would be: 19 gauge = 125 ft, 22 gauge = 62 ft, 24 gauge = 40 ft, 26 gauge = 25 ft.

### Voltage

Voltage is the measurement of electromotive force or difference in potential between two points. Formulas use the letter V or E. Voltage measurements are expressed in terms of alternating current (AC) or direct current (DC). Typical U.S. household voltage is 120 volts AC. Typical automobile batteries are 12 volts DC. AC voltage can be converted to DC voltage through diode bridges called rectifiers. Voltages can be increased or decreased through the use of transformers that either step up or step down the voltage level through a ratio of turns between the input (primary) and the output (secondary) coils.

## **Current**

Current is the rate of flow of electricity through a circuit. In simple terms, it is the number of electrons that flow past a specified point in one second of time. Current is measured in amperes using the letter A in the measurement and the letter I in formulas. A typical circuit breaker for a house is rated at 15A or 20A. Current flow in telephone circuits and electronics is usually in the milliampere (mA) range. A milliamp is 1/1,000<sup>th</sup> of an ampere (1mA = .001A).

## **Resistance**

Resistance is the opposition to the flow of electricity in a circuit. The length and diameter of a wire or cable pair affects the total resistance in a circuit. Other factors like temperature and humidity have some affect on resistance as well. Resistance increases as the wire diameter decreases. Resistance is measured in Ohms and is identified by the omega ( $\Omega$ ) symbol. Formulas use the letter R. Different materials offer different amounts of resistance. Conductors offer little resistance while insulators offer high resistance. A multi-stranded wire has less resistance than a solid single-strand wire because the multi-stranded wire has more surface area for the electrons to travel on than a solid wire.

## **Ohms Law**

Ohms Law is a formula used to calculate voltage, current, and resistance when any two of these values are known. The formula is expressed in three different variants depending upon which values are known and which value is to be calculated. The variants are:  $E = IR$ ,  $I = E/R$  and  $R = E/I$ . This means that voltage is directly proportional to the current multiplied by the resistance. Current is calculated by dividing the voltage by the resistance; and resistance is calculated by dividing the voltage by the current. Therefore, we can observe that the higher the voltage, the higher the current flow; and the higher the resistance the lower the current flow.

## **Capacitance**

A capacitor is a device that stores an electrical charge and usually consists of two conductive plates separated by an insulator. A twisted pair of wires with insulation acts much like a capacitor when voltage is applied to the pair. A capacitor blocks DC voltage. Capacitance is referred to as the ability to hold an electrical charge and is present on telephone cables. The unit of measurement for capacitance is the farad, although micro and pico-farad measurements are most commonly encountered. Larger gauge wires and longer runs of wire have more capacitance on them. The greater the capacitance there is on a twisted pair, the greater the voice signal loss. Insulation, thickness, and spacing of wires affect the capacitance in a cable.

## Capacitive Reactance

Basically, reactance is to an AC circuit what resistance is to a DC circuit. Reactance, however, is affected by the value of the component and the frequency of the circuit in which it is being used. Capacitive reactance, commonly expressed as  $X_c$ , is inversely proportional to the value of the capacitor and the frequency. The formula is  $X_c = 1/2\pi fC$ , where  $X_c$  is calculated by dividing one by (two times the value of Pi times the frequency times the capacitance); Pi ( $\pi$ ) = 3.1416. Therefore, we can observe that  $X_c$  increases as frequency or capacitance decreases and  $X_c$  decreases as frequency or capacitance increases. Larger gauge wires and longer runs of wire have more capacitance on them which calculates to lower capacitive reactance. As the frequency increases, the capacitive reactance also decreases. Lower reactance, like lower resistance, appears more like a short as the value approaches zero.

## Inductance

An inductor is a coil of wire that can be used to increase the inductance in a circuit. Inductance is resistance to any change in current flow and slows down the rate of change. Inductance is the result from a magnetic field that surrounds a wire when current flows through the wire. The number of turns in the coil and the rate of the change of current through the coil determines the inductance. Inductance is measured in henrys, though millihenrys is the common range of measurements.

Telephone circuits use load coils as inductors to increase the circuit inductance. Increasing inductance counteracts capacitance thereby stabilizing current flow (voice signals). A cable equipped with load coils is said to be a loaded cable. The most common loading scheme is called H88 because 88mH coils are used and they are spaced at 6,000 foot intervals.

## Inductive Reactance

Inductive reactance, like capacitive reactance, is affected by the value of the component and the frequency of the circuit in which it is being used. However, inductive reactance, commonly expressed as  $X_l$ , is directly proportional to the value of the inductor and the frequency. The formula is  $X_l = 2\pi fL$ , where  $X_l$  is calculated by multiplying (two times the value of Pi times the frequency times the inductance); Pi ( $\pi$ ) = 3.1416. Therefore, we can observe that  $X_l$  increases as frequency or capacitance increases and  $X_l$  decreases as frequency or capacitance decreases. Higher reactance, like higher resistance, appears more like an open as the value approaches infinity.

## Power Formulas

Like Ohms law, power formulas use several variants of a formula to calculate power. Voltage, current, and resistance can be used to calculate power when two of these three values are known. Power, in electrical terms, is expressed as Watts using the letter W as its symbol in measurements and the letter P in formulas.

The formula variants are:  $P = IE$ ,  $P = E^2/R$ ,  $P = I^2R$ . This means that power is directly proportional to the current multiplied by the voltage. Power can also be calculated by dividing the voltage squared by the resistance or by multiplying the current squared by the resistance. If the power is known, then using the formulas can help in determining the voltage or current or resistance values.

## CONNECTING TO OUTSIDE PLANT

The Sidekick comes with three test leads; red, black and green. The red test lead is connected to the Ring wire of a twisted pair, the black lead to the Tip wire of the twisted pair, and green to ground. It is extremely important to have a good ground connection. Erroneous test readings may occur when a good ground is not present.

Verify that the test connections are good before starting a test. Make sure the test lead clips are securely connected to the wires and that the ground clip is connected properly to a good ground. When disconnecting the test lead clips, always squeeze to open the clips before removing them from the wire. **Do not forcibly pull the clips off the wires or ground connections.** Damage to the test lead and wires can occur.

Typical outside plant places the Central Office (CO) battery on the Ring line and ground on the Tip line. The customer's line is connected between Tip and Ring. The line circuit is the CO battery running through the Ring line to the telephone and through Tip to ground. When the customer's telephone is on-hook (hung up), the circuit is incomplete and current can not flow. When the phone is picked up (receiver off hook) the path is complete and current can then flow to ground.

## FAULT TYPES

Faults are caused by many factors including materials and workmanship. Care must be exercised when performing any repairs or installations. Construction work near buried or overhead cables can easily lead to damaged lines.

There are several types of electrical faults. The most common are opens, shorts and grounds. Other common telephony faults include resistance faults, noise, line imbalance, crosses, splits, power influence, induction, circuit loss, and low loop current. Multiple faults can occur simultaneously. Each of these fault types are discussed in the following paragraphs.

## **Opens**

Typically, an open is a physical break in the transmission line that prevents any signal or electrical current from flowing past the break. An open can occur on either the Tip or Ring line, or both at the same time. Usual symptoms are no dial tone or the line is out of service. Extremely high resistance can also appear as an open. An open can occur when other faults are present.

## **Shorts**

A short usually occurs when two conductors physically touch each other. But a short can also occur when water, dust, or other matter causes the signal or current to divert onto another path. The affect on service depends on the severity of the short. A short can occur when other faults are present.

## **Grounds**

A ground usually takes current or a signal out of the loop; it can occur on either the Tip or Ring line, or both at the same time. The usual symptom is a loud hum noise. A ground fault can occur when other faults are present.

## **Resistance Faults**

Resistance affects the ability of current to flow in a conductor. Excessively high resistance will appear as an open effectively blocking the flow. High resistance can be attributed to a breakdown in the electrical characteristics of the conductor or physical damage to the conductor.

## **Noise**

Noise in a communications system can be any unwanted signals or disturbance. Noise is typically heard as any detriment to the clarity of a signal usually as static or hum. In an unbalanced Tip and Ring pair, current levels are unequal which can induce audible noise.

## **Line Imbalance**

When the electrical characteristics of each conductor in a Tip and Ring pair are not the same, the pair is unbalanced. The imbalance of a pair can cause noise in the circuit.

## **Crosses**

A cross occurs whenever a Tip or Ring conductor of one pair touches a Tip or Ring conductor of another pair. A battery cross occurs when a Tip or Ring conductor in a pair touches another Ring conductor.

## **Splits**

Splits occur when the Tip or Ring conductor of one pair is transposed with the Tip or Ring conductor of another pair.

## **Power Influence**

Power Influence is the noise that is present from AC inductance upon a cable or pair. In a balanced pair, the noise due to power influence is not audible. In an unbalanced pair, the noise is audible. Power influence is typically caused by poor bonding and grounding of the cable shield.

## **Induction**

Induction occurs when a changing magnetic field causes current to flow in a wire. Telephone lines are susceptible to induction from AC circuits and other telephone wires. Induction from AC circuits usually imparts an audible hum on the line. Cross talk is caused by the induction from other telephone lines. In a well balanced pair, noise is not usually heard.

## **Circuit Loss**

Signal power lost between the milliwatt supply of the CO and the station protector is known as circuit loss. Symptoms are: inability to call out, hear, or be heard. Improper cable assignment, low loop current, excessive bridge taps, and high resistance are typical causes for loss.

## **Loop Current**

Loop Current is the amount of current in milliamps that flows from the CO through the loop and back to the CO. Loop current is required for dial tone requests, touch-tone pad operation, ring trip when a call is answered, and talk battery to the transmitter. Low loop current symptoms include: no dial tone, wrong number dials, can't hear, and can't answer. This is usually caused by corroded connections, excessive loop resistance or missing range extenders.

# SideKick 7B

## General Description

The Sidekick 7B is *the* test set used by every major telephone company in the United States to troubleshoot twisted pair applications. This lightweight, hand-held meter quickly and accurately uncovers intermittent troubles that other test sets cannot detect. Since the introduction of the patented *Stress* test and *Leakage* test in 1991, the Sidekick has become a benchmark in communications technology. Technicians now have the versatility to identify faults in locations ranging from outside plant cable to inside wiring; and from closures to connecting blocks without sacrificing standard features such as the AC/DC, VOM, and Kick Meter features they have come to rely on. The versatile Sidekick 7B is used throughout the telephony industry including; LAN/WAN, Private Networks, and BICSI applications.

The patented *Stress* test measures the audible noise produced on a faulted pair when it is stressed as a result of a 90 dBmC longitudinal excitation. This test determines the capacitive and series resistance balance characteristics of a twisted pair at any point along the pair. It is capable of identifying DC resistive or capacitive imbalances undetected by other subscriber loop tests. The *Stress* test is also highly effective in identifying imbalances produced by series resistance opens (high joints).

The *Leakage* test detects intermittent resistance faults that do not appear under normal VOM tests. When a faulted pair is taken out of service, galvanic action forms an insulating oxide layer over the faults. When returned to service, such pairs develop "noisy static" in a relatively short period of time. The *Leakage* test uses 135 Volts DC to "punch through" the galvanic corrosion, thus revealing the fault.

## Features

- Stress Test
- Leakage Test
- Volt-Ohmmeter
- Kickmeter
- Analog meter provides instant readout
- Low battery warning indicator
- Handset (buttset) terminals
- Field replaceable test leads
- Single hookup for Tip-to-Ring, Tip-to-Ground, and Ring-to-Ground testing
- Minimal drying effect in all ranges
- Simplex tone
- Automatic shut-off

## Benefits

- Improves customer satisfaction
- Reduces repeat service calls
- Eliminates service interruptions
- Works on any twisted pair application
- Increases service productivity
- Provides quick return on investment

## Front Panel Controls

**Mode Switch:** Selects the following functions:

**Off** - Powers the Sidekick off.

**AC Volts** - Measures 0-200 AC Volts on the black scale.

**DC Volts** - Measures 0-100 DC Volts on the black scale.

**Stress Test** - Measures the audible noise produced while stressing a pair with a balanced longitudinal signal approximating a 90 dBmC power influence; read-out is in decibels above reference noise, C-message weighted (dBmC) on the meter's black scale.

**Leakage (RX10K)** - Ohms circuit that applies 135 VDC to a pair to reveal resistance faults masked by galvanic corrosion; measures resistance with mid-scale (red) at 1,000,000 ohms; performs capacitive "Kick".

**RX1K** - Measures resistance with mid-scale (red) at 100,000 ohms; performs capacitive "Kick".

**RX1** - Measures resistance with mid-scale (red) at 100 ohms.

***NOTE:** The Sidekick's Leakage RX10K, RX1K, and RX1 switch labels are color-coded to match the meter's red ohms scale.*

**Rev Switch** - Reverses the polarity of the test being performed; acts as the Kickmeter switch in the RX10K and RX1K positions.

**Tip Switch** - Provides measurement from Tip-to-Ground.

**Ring Switch** - Provides measurement from Ring-to-Ground.

**7B Meter** – Red ohms scale measures Fault Resistance. The black scale measures 0 to 200 AC Volts; 0 to 100 DC Volts; 0 to 100 dBmC of Stressed Noise; and Capacitance Kick (point scale).

**Low Battery Indicator** – LED flashes once a second to indicate failing batteries; remains lit when measurement accuracy is compromised – replace the batteries immediately.

**BEFORE YOU START ANY FAULT TESTING**, you should check for AC and DC voltage. It's rare to find AC on a POTS line, but it does happen. **ALWAYS check for AC BEFORE you check for DC.**

## **AC Volts Test**

The AC Volts function tests for the presence of AC voltage on the pair.

To check for AC volts,

1. Turn the **MODE SWITCH** to the **OFF** position.
2. Connect test leads; Black, Red, and Green to; Tip, Ring, and Ground.
3. Turn the **MODE SWITCH** to **AC VOLTS**.
4. There should be **MINIMAL** AC voltage. If AC voltage is 50 volts or above, **STOP** immediately and remove the AC voltage before continuing.

## **DC Volts Test**

The DC Volts function tests for battery presents on both working and dry pairs.

Why check for DC voltage? There are three reasons:

1. DC power is required to make a POTS line work.
2. DC Volts indicates CO battery presence.
3. DC should not be found on a Dry, Vacant, or Nonworking line. *Dry*, *Vacant*, and *Nonworking* all mean the same thing – not in service. If DC volts are found on a Dry, Vacant, or Nonworking pair, it is crossed with a Working pair.

To check for DC Volts,

1. Turn the **MODE SWITCH** to the **OFF** position.
2. Connect test leads; Black, Red, and Green to; Tip, Ring, and Ground.
3. Turn the **MODE SWITCH** **DC VOLTS**.
4. The **REVERSE SWITCH** should be in its normal position, **UP**. If DC voltage is present, the meter will read 48 - 52 volts. Remember, the meter is looking across the pair and will read zero or negative volts if the pair is reversed. The pair is **reversed** when the **REV SWITCH** is **DOWN** and the meter reads 48-52 positive volts. While in the DC mode, you can check **Tip-to-Ground** and **Ring-to-Ground** by holding the **TIP** or **RING SWITCH** **UP**.

## Quiz 1

1. The red scale on the Sidekick 7B meter is used to read AC or DC voltages.  
T  
F
2. The DC Volts test can be used to indicate:
  - a) CO battery presence
  - b) battery cross on vacant pairs
  - c) both A and B above
  - d) none of the above
3. What voltage range is acceptable for a CO battery?
  - a) 0-100 Vdc
  - b) 48-52 Vdc
  - c) 48-52 Vac
4. The red test lead is connected to the Ring wire in a pair and the black wire is connected to the Tip wire.  
T  
F
5. To switch from AC Volts to DC Volts the Reverse switch is used.  
T  
F
6. When measuring AC voltage with the Sidekick, the reading on the meter scale must be:
  - a) multiplied by 2
  - b) divided by 2
  - c) read directly off the red scale
7. For Tip-to-Ground measurements, the Tip switch is:
  - a) held down
  - b) not used
  - c) held up
8. For Ring-to-Ground measurements, the Ring switch is:
  - a) held up
  - b) not used
  - c) held down

9. To detect battery on the Tip wire:
- a) use the AC Volts test and toggle the REV switch to the DOWN position.
  - b) use the DC Volts test and hold the Tip switch UP.
  - c) use the AC Volts test and hold the Tip switch UP.
  - d) use the AC Volts test and hold the Ring switch UP.
10. With the Sidekick, the presence of AC voltage can only be detected in the ACVolts test mode.

T  
F

## Stress Test

When the *Stress* test is initiated, the Sidekick stresses the pair with a 90 dBrnC longitudinal signal. This signal drives current through any series resistance fault on the pair. The series resistance converts the longitudinal current into *Metallic Voltage* at the fault which produces the high Stressed Noise. Do not confuse Stressed Noise (dBrnC) readings with Noise Metallic (dB) readings taken from a Subscriber Loop Test Set. The *Stress* test is more sensitive to pair imbalances than Noise Metallic and Longitudinal Balance tests.

During the *Stress* Test, a 1000 Hz simplex unregulated trace tone reading approximately 90 dBrnC is transmitted simultaneously with approximately 135 applied Volts DC. This tone is used to trace a pair using any standard inductive amplifier. The tone is inaudible to the subscriber as long as Tip, Ring, and Ground are connected and the line is balanced. If the Tip or Ring test lead is disconnected during testing, or the line is unbalanced, the tone becomes audible and increases as line imbalance increases. Nonworking-Idle and Working-Idle line conditions are ideal for this test.

Since the Sidekick does not draw loop current when the *Stress* test is performed, there's no need to dial a Quiet Termination for on-hook measurements. This is an advantage over standard noise measurement sets that draw loop current which can mask some faults.

## Fault Types Identified

The *Stress* test identifies and isolates:

- High Joints or High Resistance Opens (Series Resistance Faults)
- Capacitive Imbalances (Conductor Lengths are Unequal)
- Unbalanced Load Coils or Build-Out Networks
- Crosses
- Grounds
- Split Pairs

**NOTE:** *The Stress test does not identify shorts since a shorted pair is balanced and will produce good stressed noise readings. Use the Leakage test to identify shorts.*

## Proper Ground

If the Sidekick is properly connected to a pair but lacks a solid ground connection, **the reading will be inaccurate.**

To verify good ground:

1. Turn the **MODE SWITCH** to the **OFF** position.
2. Connect test leads; Black, Red, and Green to; Tip, Ring, and Ground.
3. Turn the **MODE SWITCH** to **STRESS TEST**.
4. **Remove** either the **TIP** or **RING** test lead.

The ground is good if 70 dBrnC or higher is displayed. Lower readings may indicate a defective Ground or Short Loop.

### **Procedure**

***NOTE:** Perform this test by bridging across the pair at any point along its length or by opening the loop and testing in each direction. Performing a final test from the subscriber's protector (SNI, NI, etc.) is recommended. Do not operate any switches while performing this test. No damage to the test set will occur, however, readings will be incorrect.*

1. Turn the **MODE SWITCH** to the **OFF** position.
2. Connect test leads; Black, Red, and Green to; Tip, Ring, and Ground.
3. Turn the **MODE SWITCH** to **STRESS TEST**.
4. To stress the pair, toggle the **REV SWITCH UP**. A trace tone is transmitted through the pair for tracing or to detect cross-talk.
5. Read the Stress Noise level on the black scale.

### **Identifying a Pair or Cross Conductor**

1. Using an inductive amplifier (standard probe), listen for tone. Tone will be strongest on the pair under test.
2. To identify crossed conductors, listen for tone carry-over on adjacent conductors. Tone on the crossed conductor will be louder than tone on adjacent conductors.

***NOTE:** When tracing pairs, keep in mind that the Sidekick will "time-out" after nine minutes inactivity.*

When performing the *Stress* test on complete end-to-end circuits, use the following Stress Test Evaluation Scales to determine pair quality.

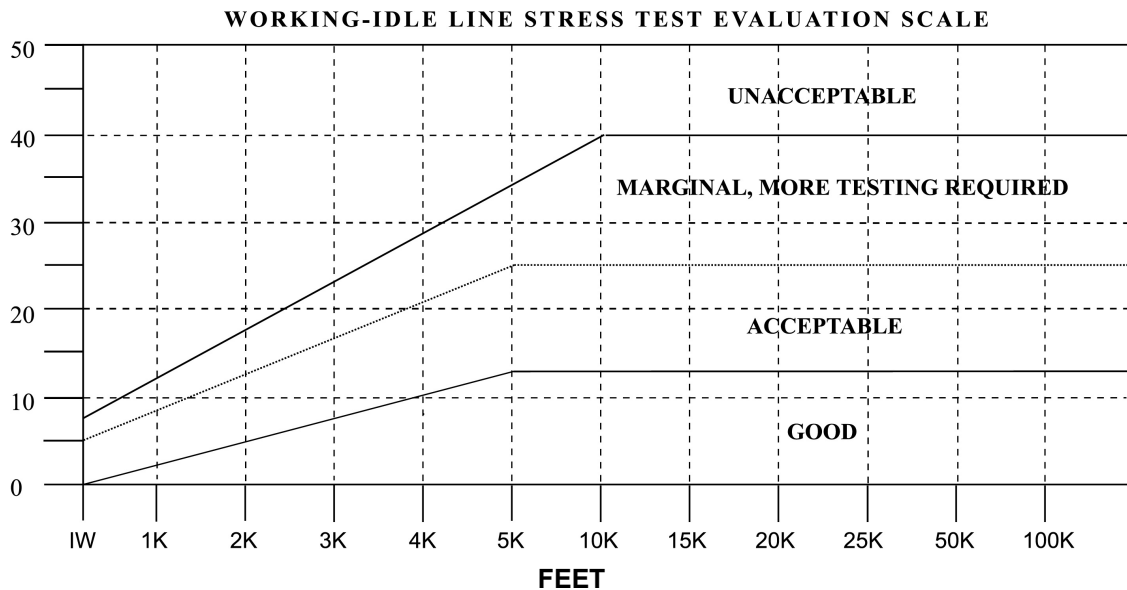
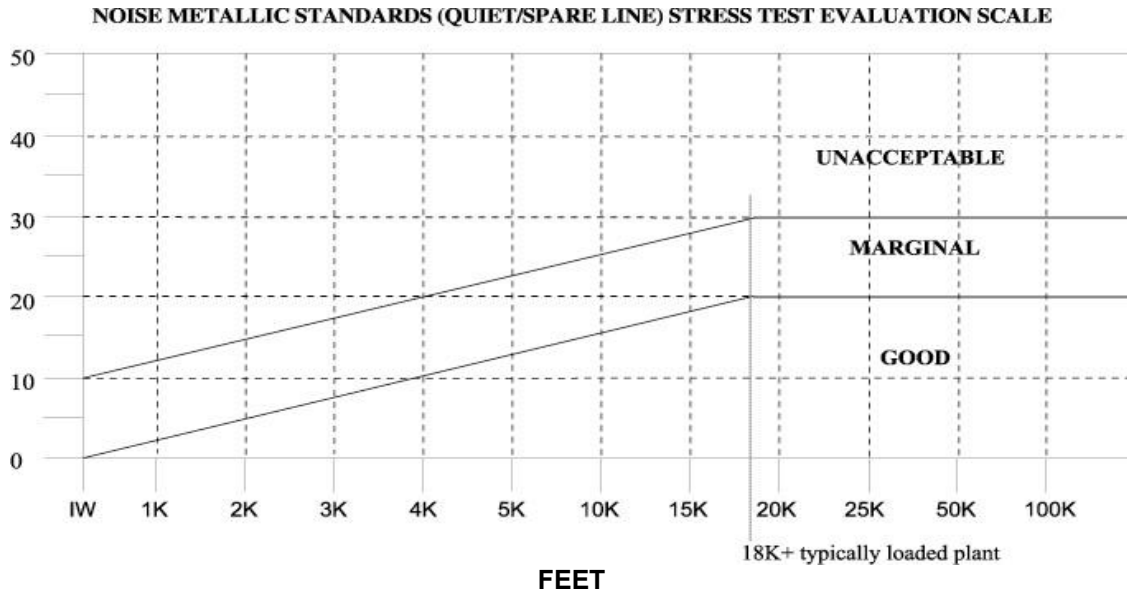

The following Noise Metallic readings, as a general rule, may be used as a guide to determine pair quality.

- Stress Test: Measured in dBrnC
- Scale: 0 to 90 dBrnC
- Acceptable: 0 to 20 dBrnC
- Marginal: 20 to 30 dBrnC (test further)
- Unacceptable: 30 dBrnC or higher

These ranges assume that little or no additional influence is present on the pair from the C.O. or Remote Terminal Units. Refer to the graphs and notes in the Sidekick's Operating Manual Appendixes for expected results.

Use the following testing tips if readings greater than 30 dBrnC are observed on Working-idle or On-hook working circuits:

1. Isolate the pair from the C.O. and retest to determine the effect of electronic equipment on the Stressed Noise readings in a given service area. To confirm that electronic influence is not service-affecting, Stressed Noise readings must drop to acceptable levels when performing an Off-hook test. If sampled pairs continue to test high, cable-related trouble, such as poor bonding or grounding may be the cause.
2. Since Stressed Noise readings are slightly higher due to the controlled longitudinal excitation placed on a pair, it is advisable to sample adjacent pairs to determine "normal" Stressed Noise levels for a particular service area. The closer a pair is to, or below, the relative reading, the better its performance. When performing comparison testing, a 10 dBrnC or greater difference between pairs indicates trouble on the pair with the higher reading.

*NOTE: The shorter the cable or conductor, the lower the reference readings.*

### **Bridged Stressed Noise Readings**

A bridged reading represents the average of the Stressed Noise readings taken in each direction. Therefore, when you open a pair that exhibits a bridged reading of 25 dBrnC at the cross connect, it may actually read 18 dBrnC toward the C.O. and 32 dBrnC toward the field. If adjacent pairs exhibit the same reading, you may not be able to improve the quality of the line. In this case, proceed with Trouble Isolation.

### **Trouble Isolation**

If a pair has been reported as "intermittently noisy", first divide the pair into distinct sections. To reduce repeat service calls, leave the customer with a pair that tests at or below the adjacent pairs in each section.

To isolate Series Resistance faults:

1. Test from the far end, toward the C.O.
2. Test in both directions to determine if there is a difference in the readings.
3. Compare the readings produced by other pairs

**TIP:** Short and ground the pair at the far end. Using the *Resistance* test, measure each side to ground. The highest reading is the Series Fault.

## **Stress Test Effectiveness**

The *Stress* test identifies capacitive imbalances (i.e., unequal conductor lengths) and DC problems (i.e., crosses and grounds) anywhere along the length of a Dry or Idle Working pair. However, Series Faults (i.e., high resistance opens and bad splices) that cause static noise on a single wire will read below 30 dBnC if there is less than 1,000 feet of wire beyond the fault!

Example: A test is performed from the cross-connect box toward the customer premise with the fault located somewhere between the technician and the customer. The Sidekick may not display high Stressed Noise readings (over 30 dBnC) if less than 1,000 feet of wire lies beyond the fault. Therefore, in Short Loop testing, if the noise reading is higher than other pairs sampled in the binder group, there may be a Series Fault in the pair. Testing from the customer end toward the C.O. will confirm this.

## **Questionable Cables**

As a cable deteriorates, the Stressed Noise readings on all pairs will begin to rise. To reduce repeat service calls, use the pair with the lowest reading.

## **Equipment Balance**

The *Stress* test is also effective in isolating poorly balanced C.O. equipment. In this case, test toward the field, then toward the switch at the mainframe. Use the same Stressed Noise criteria for C.O. equipment as for a line. Mechanical C.O.'s (i.e., #1 x BAR, #5 x BAR, S x S) tend to exhibit higher Stressed Noise readings in an idle state. To compensate, perform the *Stress* test with the battery removed. In addition, the #5 ESS-type C.O. occasionally pulses the Sidekick in the *Stress* test mode. The pulse is rhythmic and usually measures just 2-4 dBnC.

Range Extenders (5A Regs) on a customer line will appear unbalanced in an idle state. As a result, Stressed Noise readings will be high. If you know, or suspect, that there is a 5A Reg on the line, perform the *Stress* test with the battery removed.

Litespan®-2000 systems will cause a line to exhibit higher than normal Stressed Noise readings (approximately 40 dBnC) due to equipment termination. Either disconnect the line on the Litespan®-2000 side or test good lines in the area to determine normal noise readings.

## Testing DSSC, DAML, OR UDC Pair Gain Line

DSSC, DAML, and UDC pair gain lines carry approximately 70 to 130 VDC between the Central Office Terminal (COT) and the Remote Terminal Unit (RTU) located at the subscriber end. These lines also exhibit Stressed Noise readings of 80 dBrnC and higher in the *Stress* test mode. The excessive voltage on these lines will not harm the Sidekick but the readings become invalid. To ensure accurate readings when testing pair gain lines, follow the simple rules listed below:

1. Be familiar with local procedures when disabling a pair gain system that serves more than one customer.
2. If local procedures permit, disconnect the C.O. pair from the RTU. Or, if so equipped, use the disconnect switch on the RTU to isolate the C.O. pair. The line running between the COT and RTU will revert to a POTS line in approximately 60 seconds. Perform Sidekick tests as usual.

*NOTE: Because it is normal for the COT to transmit a 130 VDC pulse every one (1) to five (5) minutes, the meter will also pulse.*

3. Full path (subscriber to C.O.) testing can be accomplished by disconnecting and jumping past the RTU.

*NOTE: Testing pair gain lines from the subscriber side (instrument to RTU) can be done without disabling or disconnecting the RTU.*

## Troubleshooting Tips

The closer you are to the source of the trouble, the higher the Stressed Noise readings will be. Example: If a pair exhibits a reading of 40 dBrnC on the F2 distribution at the cross-connect and a reading of 50 dBrnC at the protector/SNI, you can assume that the trouble is closer to the customer premise. If Stressed Noise readings decrease (below 50) as you move toward the cross-connect or beyond the customer's serving terminal, you can assume that you were closer to the trouble at the protector/SNI.

The Sidekick will read pulses sent across the pair from Maintenance Test Units (MTUs) in the *Leakage* test mode. If this happens, simply set the *Reverse* switch to the opposite position. MTUs will also create an imbalance on the line when you test from the customer side. To compensate, remove the MTU from the line while performing the *Stress* test from the customer side.

Construction Wire ("C" Rural) will produce high Stressed Noise readings (50+ dBrnC). In this case, simply verify that the wire reads the same at both ends. The following examples illustrate some typical faults. Readings of 30 dBrnC at the cross-connect are taken with the jumper in place. Readings given for the C.O., F1, and F2 are taken with the jumper disconnected. All readings are in dBrnC units.

1. Trouble in C.O.

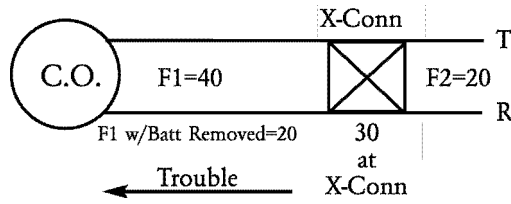

2. Trouble in F1

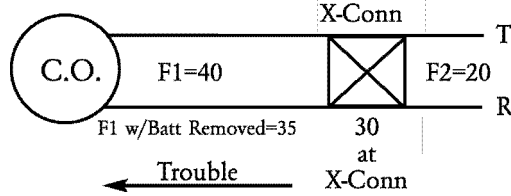

3. Trouble in F2

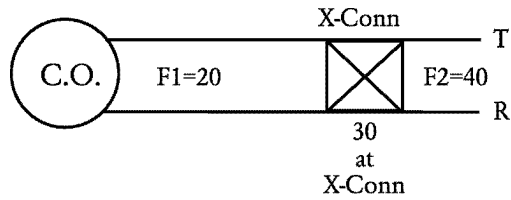

4. Trouble Isolation in F2

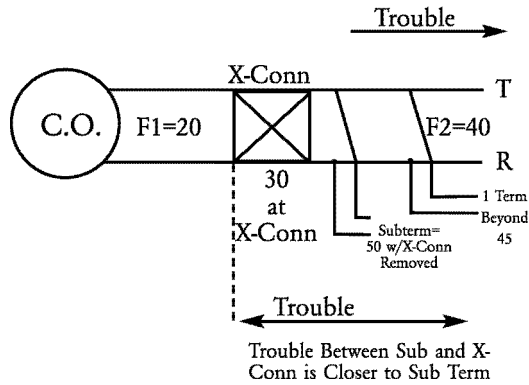

5. Trouble (Hi-Resistance Open) in Drop

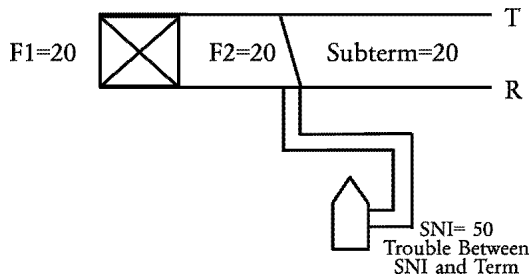

6. Trouble in F2: Beyond Sub.

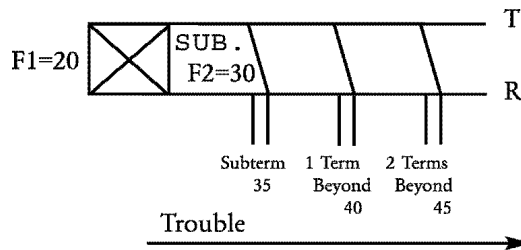

## Quiz 2

1. The Stress test identifies and isolates the following faults:
  - a) high resistance or series opens
  - b) split or crossed pairs
  - c) unequal conductor lengths
  - d) all of the above
  
2. When using the Stress test, the signal used to stress the pair is:
  - a) a 90 dBrnC longitudinal signal
  - b) a 90 dB noise metallic signal
  - c) a complex tone to warn the customer of a test
  
3. The Stress test drives current through any series resistance on the pair.  
T  
F
  
4. At the fault, longitudinal current is converted into:
  - a) a simplex tone
  - b) a metallic voltage
  - c) a noise metallic reading
  - d) a loop imbalance resistance
  
5. The Stress test can identify shorts in a Balanced pair that is shorted.  
T  
F
  
6. The Sidekick does not draw loop current in the Stress test mode.  
T  
F
  
7. The Stress test can be used to test:
  - a) Working pairs only
  - b) Idle pairs only
  - c) both Working and Idle pairs
  - d) Shorted pairs

8. An acceptable dBrnC reading in the Stress test would be in the range:
- a) 30-70 dBrnC
  - b) 35-50 dBrnC
  - c) 0-90 dBrnC
  - d) 0-30 dBrnC
9. As the Sidekick gets closer to the fault, the readings on the meter when in the Stress test will:
- a) increase
  - b) decrease
  - c) fluctuate rapidly
10. In order for the Stress test's simplex tone to be inaudible to the customer, the following Sidekick test leads must be connected:
- a) Tip and Ground only
  - b) Tip, Ring and Ground
  - c) Ground only
  - d) Tip and Ring only

# Leakage and Resistance

## Leakage Test

The *Leakage* test detects intermittent Resistance Faults that do not appear under normal VOM tests. When pairs with Resistance Faults are vacant, galvanic action forms an insulating oxide layer over the faults leaving them undetectable to standard ohmmeters. When placed into service, such pairs develop “noisy static” in a relatively short time. The *Leakage* test is an ohmmeter that uses 135 VDC to “punch through” the galvanic corrosion, thus revealing the fault.

*NOTE: The Sidekick’s internal, 1 Megohm impedance causes this voltage to appear as approximately 135 Volts when measured by an instrument with 10 Megohms of impedance.*

## Procedure

**CAUTION:** Always test for, and remove any AC and DC voltage present on the pair before performing the *Leakage* test.

**TIP:** Perform the *Leakage* test in this sequence to allow the 135 VDC to “punch through the galvanic corrosion” on the pair.

1. Turn the **MODE SWITCH** to the **OFF** position
2. Connect test leads; Black, Red, and Green to; Tip, Ring, and Ground.
3. Verify that the **REV SWITCH** is toggled to the **UP** position
4. **To test Tip-to-Ring**, turn the **MODE SWITCH** to **LEAKAGE RX10K**. Then wait approximately 15 seconds. Next, toggle the **REV SWITCH** to the **DOWN** position. Again, wait approximately 15 seconds.
5. Read the metered Leakage value.

*NOTE: The Leakage value is determined by multiplying the ohms reading on the meter’s red scale by 10,000; it should remain steady at or above 3.5 megohms\* during every segment of the test sequence.*

6. **To test Tip-to-Ground**, toggle and hold the **TIP SWITCH UP** for approximately 15 seconds. Then toggle the **REV SWITCH** to the opposite position and wait approximately 15 seconds.
7. **To test Ring-to-Earth**, toggle and hold the **TIP SWITCH UP** for approximately 15 seconds. Then toggle the **REV SWITCH** to the opposite position and wait approximately 15 seconds.

\*Per Bellcore standards, pairs exhibiting readings below 2 megohms are unacceptable. However, according to general practice, pairs exhibiting leakage reading between 2 and 3.5 megohms are still acceptable. Refer to specific company practices for acceptable megohm readings.

## Resistance Test

The *Resistance* test measures the resistance level of a pair's line(s) by placing low voltage on the test leads and reading the current flow from either the Tip-to-Ring, Tip-to-Ground, or Ring-to-Ground wire depending on the switch position. From Ohm's Law, the resistance is calculated from the voltage and current. Resistance and current are inversely proportional. Therefore, as resistance *increases* current *decreases* and as current *increases* resistance *decreases*. If the circuit appears open in this test (>1 megohms), the *Leakage* test RX10K should be performed to check resistance up to 100 megohms.

### Procedure

**CAUTION:** Always test for, and remove any AC and DC voltage present on the pair before performing the *Resistance* test.

1. Turn the to **MODE SWITCH** the **OFF** position.
2. Connect test leads; Black, Red, and Green to; Tip, Ring, and Ground.

**NOTE:** *The following **Rx** selections represent the resistance value (in ohms) on the meter's red scale.*

- A. **Rx 1** – for meter readings up to 1,000 ohms.
  - B. **Rx 1K** – multiplies meter readings by 1,000.
  - C. **Rx 10K** – multiplies meter readings by 10,000.
3. **For Tip-to-Ring;** turn the **MODE SWITCH** to the appropriate **Rx** scale to read the resistance (in ohms) on the meter's red scale.
  4. **For Tip-to-Ground;** toggle and hold the **TIP SWITCH** in the **UP** position. Then read the meter.
  5. **For Ring-to-Ground;** toggle and hold the **RING SWITCH** in the **UP** position. Then read the meter.

### Resistance/Conductor Length (Approximate)

If a pair's ohms reading indicates a Solid Fault (as verified by 0 ohms change when polarity is reversed), the approximate distance to the fault can be determined from Loop Resistance.

**NOTE:** *Any Series Resistance at the fault will cause the distance to appear longer than it actually is. Do not use the ohms reading unless you are sure there is metallic contact at the fault. Gauge changes and temperature also introduce errors. For accurate fault location, use a Resistance Bridge.*

# Capacitive Kick

## Kickmeter

A conductor has capacitance to Ground or to other conductors within a cable proportional to its length. In the RX1K and RX10K modes, this capacitance is charged by the Sidekick's battery. Changing the position (throw) of the *Reverse* switch not only reverses polarity, but creates a sudden capacitive discharge causing the meter's needle to "Kick".

*NOTE: A capacitive imbalance is indicated when both sides of the pair do not kick equally.*

## To Kick a Pair

1. Turn the to **MODE SWITCH** the **OFF** position.
2. Connect test leads; Black, Red, and Green to; Tip, Ring, and Ground.
3. Turn the **MODE SWITCH** to the appropriate Ohms scale; RX1K for conductors over 5,000 feet and RX10K for conductors under 5,000 feet.
4. **To kick Tip-to-Ring** – Toggle the **REV SWITCH** and observe the peak meter deflection on the black 100-point scale. Then toggle to return the **REV SWITCH**, an equal kick should be observed. Allow the meter to settle between kicks. A very large kick indicates ringer presence.
5. **To kick Tip-to-Ground** – Hold the **TIP SWITCH UP** and toggle the **REV SWITCH** while observing the peak meter deflection on the black 100-point scale. Then toggle to return the **REV SWITCH**, an equal kick should be observed. Allow the meter to settle between kicks. A very large kick indicates ringer presence.
6. **To kick Ring to Ground** – Hold the **RING SWITCH UP** and toggle the **REV SWITCH** while observing the peak meter deflection on the black 100-point scale. Then toggle to return the **REV SWITCH**, an equal kick should be observed. Allow the meter to settle between kicks. A very large kick indicates ringer presence.

*NOTE: In the RX1K mode, each point on the scale represents approximately 500 feet. In the RX10K mode, each point represents approximately 50 feet.*

## Capacitance/Conductor Length (Approximate)

If a pair's ohms reading indicates a Solid Fault, as verified by 0 ohms change when polarity is reversed, the approximate distance to the fault can be determined from Loop Resistance.

To determine the approximate length of a conductor, compare the pair's kick reading to the Kickmeter Conversion Chart found in Appendix C of the Sidekick's Operating Manual. If a pair is open on one side, only the shorter side will produce an accurate reading. For an accurate length measurement, use an Open Locator.

**Note:** *Any Series Resistance at the fault will cause the distance to appear longer than it actually is. Do not use the ohms reading unless you are sure there is metallic contact at the fault. Wire gauge changes and temperature also introduce errors. For accurate fault location, use a Resistance Bridge*

### Quiz 3

1. The Leakage test can be used to detect intermittent resistance faults in a pair?  
T  
F
2. The Leakage test uses what voltage to “Punch through” the oxide layer?
  - a) 10,000 Volts DC
  - b) 135 Volts DC
  - c) 90 Volts DC
  - d) 135 Volts AC
3. In the Leakage test, how long should the Tip and Ring switched be held up to allow the voltage to “Punch through” the oxide layer?
  - a) 30 seconds
  - b) 3-5 seconds
  - c) 1 second
  - d) 12-15 seconds
4. When reading the scale in the Leakage test, the resistance reading should be multiplied by 10,000 to determine the Leakage value.  
T  
F
5. Resistance values are read using the black scale on the Sidekick meter.  
T  
F
6. When both wires of a pair do not “Kick” equally, what fault is being detected?
  - a) capacitive imbalance
  - b) high resistance
  - c) metallic oxidation
  - d) crossed bridges
7. To “Kick a pair” is a term used to define which of the following actions when performing the Kick test?
  - a) shorting one wire in the pair
  - b) triggering a resistive discharge through the meter.
  - c) triggering a capacitive discharge through the meter.
  - d) all of the above

8. The “Kick” in the meter reading is proportional to the conductor’s:
- a) height
  - b) length
  - c) depth
  - d) gauge
9. When using the Sidekick as a “Kick” meter, which meter scale is used?
- a) black
  - b) red
10. In the RX10K mode, each point on the scale represents approximately what distance when in the “Kick” function?
- a) 10,000 feet
  - b) 50 feet
  - c) 5,000 feet
  - d) 500 feet

# Exam 1

1. The Sidekick 7B can be used to detect grounds.  
T  
F
  
2. When using the Sidekick as a kick meter, how many feet per point of “Kick” are shown in the RX1K scale?
  - a) 50
  - b) 500
  - c) 5,000
  - d) 10,000
  
3. How many feet per point of “Kick” are shown when in the RX10K (Leakage) mode?
  - a) 50
  - b) 500
  - c) 5,000
  - d) 10,000
  
4. Which of the following test functions is used to measure the longitudinal balance of a pair?
  - a) Leakage
  - b) Resistance
  - c) Stress
  - d) None of the above
  
5. The Stress test can be used to test a nonworking pair.  
T  
F
  
6. In the Stress test mode, a Working pair can be tested without removing the CO battery.  
T  
F

7. Which voltage range is considered good for a CO battery reading when testing Tip-to-Ring voltage?
- a) 48-52 Vac
  - b) 70-90 Vdc
  - c) 48-52 Vdc
  - d) 0-100 Vdc
8. To test for CO battery presence, which of the following tests is used?
- a) DC Volts Test
  - b) Stress Test
  - c) AC Volts Test
  - d) Loop Current Test
9. Which scale on the Sidekick meter is used to read the “Kick” points when in the Leakage RX10K mode?
- a) Red
  - b) Black
10. The REV switch is used to “Kick” the pair under test.
- T
  - F
11. Which of the following tests uses a 90dBmC longitudinal signal?
- a) Resistance test
  - b) Stress test
  - c) Kick test
  - d) Loop Current test
12. Which of the following tests uses 135 Vdc to detect intermittent resistance faults?
- a) Leakage test
  - b) DC Volts test
  - c) Kick test
  - d) Resistance test
13. Battery on the Tip wire can be detected by:
- a) holding the Tip switch UP in the AC Volts mode.
  - b) shorting the Tip wire to the Ring wire in the DC Volts test mode.
  - c) use the DC Volts test and hold the Tip switch UP.
  - d) none of the above

14. The Leakage (RX10K) mode can be used with CO battery on the line.  
T  
F
15. In the Stress test, an acceptable reading would be in the range of:  
a) 0-90 dBrnC  
b) 40-70 dBrnC  
c) 35-50 dBrnC  
d) 0-30 dBrnC
16. Which test is used to check for capacitive imbalance in a pair?  
a) Resistance test  
b) Leakage test  
c) Kick test  
d) None of the above.
17. Except for Inside wiring, how much cable beyond the fault is needed on a single conductor fault to ensure a good reading?  
a) none  
b) 10,000 feet  
c) 5,000 feet  
d) 1,000 feet
18. In the Stress test, a good ground can be identified with a reading:  
a) greater than 70  
b) less than 70
19. A decrease in meter reading when using the Stress test indicates that the Sidekick is getting closer to the fault.  
T  
F
20. If a customer goes off-hook during a Stress test on their line, they will hear the simplex tone being generated if the line is good.  
T  
F

# SideKick T&N

The Sidekick T&N combines the functions of the Sidekick 7B plus five new Transmission and Noise testing features. The result is a more versatile test set that identifies frequently missed faults and qualifies POTS line transmission quality. The new tests are: Loop Current; Circuit Loss; Metallic Noise; Power Influence; and Load Coil detection

**Prerequisite: Thorough working knowledge of the SideKick 7B.**

## Features

- Indicates overall circuit loss from the C.O. to point of test
- Identifies Metallic Noise levels on working lines
- Determines if noise is pair or sheath related
- Measures Power Influence on working lines
- Verifies normal Loop Current on working lines; troubleshoots low Loop Current
- Holds connection on C.O. dial-in lines when switching between Circuit Loss, Circuit Noise, and Power Influence tests
- Uses audible tone and automatic test recycle to identify up to four (4) load coils on a pair
- Color-coded meter scales and switch positions reduce user error
- Audible tone confirms power-up and high Stress Test readings

## Benefits

- Improves customer satisfaction
- Reduces repeat service calls
- Eliminates service interruptions
- Works on any twisted pair application
- Increases technician productivity
- Provides quick return on investment
- Reduces training time
- Reduces the number of test sets required

## Front Panel Controls

**Mode Switch:** Selects the following functions:

**Off** - Powers the Sidekick off.

**AC Volts** - Measures 0-200 AC Volts on the black scale.

**DC Volts** - Measures 0-100 DC Volts on the black scale.

**Stress Test** - Measures the audible noise produced while stressing a pair with a balanced longitudinal signal approximating a 90 dBnrc Power Influence; read-out is in decibels above reference noise, C-message weighted (dBnrc) on the meter's black scale.

**Leakage (RX10K)** - Ohms circuit that applies 135 VDC to a pair to reveal Resistance Faults masked by galvanic corrosion; measures resistance with mid-scale (red) at 1,000,000 ohms; performs capacitive "Kick".

**RX1K** - Measures resistance with mid-scale (red) at 100,000 ohms; performs capacitive "Kick".

**RX1** - Measures resistance with mid-scale (red) at 100 ohms.

*NOTE: The Sidekick's Leakage RX10K, RX1K, and RX1 switch labels are color-coded to match the meter's red ohms scale.*

**Rev Switch** - Reverses the polarity of the test being performed; acts as the Kickmeter switch in the RX10K and RX1K positions.

**Tip Switch** - Provides measurement from Tip-to-Ground.

**Ring Switch** - Provides measurement from Ring-to-Ground.

**Coil Detect** - Identifies up to four load coils on a pair.

**Loop Current** - Measures a circuit's loop current; read-out is in milliamps (mA) on the meter's black scale.

**PWR Influence (Power Influence)** - Measures the AC induction level on a circuit; read-out is in decibels above reference noise, C-message weighted (dBnrc) on the black scale.

**CKT. Noise (Circuit Noise)** - Measures the noise level on a circuit; read-out is in decibels above reference noise, C-message weighted (dBnrc) on the black scale.

**CKT. Loss (Circuit Loss)** - Measures the circuit attenuation level from the CO to the point of test using any of the dial-in voice range tones generated at the CO. The most commonly used tone is 1004 Hz

**T&N Meter** – The red ohms scale measures Fault Resistance. The black scale measures 0 to 200 AC Volts; 0 to 100 DC Volts; 0 to 100 mA of Loop Current ; 0 to 100 dBnrc of Stressed Noise, Circuit Noise, Power Influence, up to four load coils, and Capacitance Kick (point scale). The multicolored scale measures Circuit Loss from –15 dB to the 0 dB reference.

**Low Battery Indicator** – LED flashes once a second to indicate failing batteries; remains lit when measurement accuracy is compromised - replace the batteries immediately.

## Coil Detect Test

The Sidekick T&N can detect up to four (4) load coils on a pair. However, three (3) or fewer load coils may be detected if problems exist on a pair. Example: If the trouble is on the end segment of a pair, the fourth load coil may not be detected. Also, some CO battery and office connections can mask one or all coils from being detected if the CO battery is present.

### Procedure

**CAUTION:** Always test for, and remove any AC and DC voltage present on the pair before performing Coil Detection.

*NOTE: It is highly recommended that the CO battery be disconnected when using the Coil Detection feature. Some CO battery and office connections can mask one or all coils from detection.*

1. Turn the **MODE SWITCH** to the **OFF/DIAL** position.
2. Connect test leads; Black, Red, and Green to; Tip, Ring, and Ground.

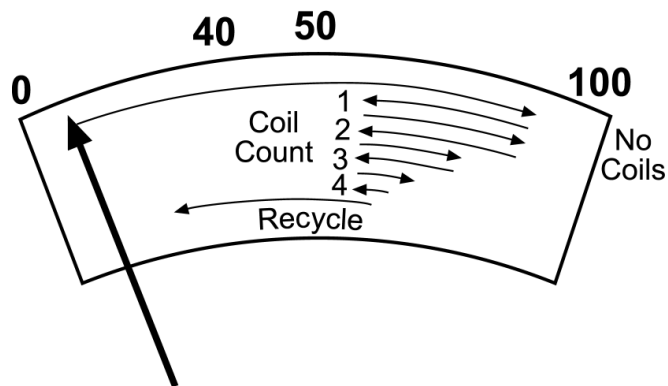

3. Turn the **MODE SWITCH** to **AC VOLTS**.
4. Verify from the meter that no AC voltage is present on the pair.
5. Turn the **MODE SWITCH** to **COIL DETECT**.
6. Refer to the following illustration for typical coil detect meter movements on the meter's black scale.
7. If the needle swings to the right, hangs momentarily, and then falls near zero; no load coils have been detected.

8. If the needle swings to the right, then falls to a position slightly above 50; a load coil has been detected.
  - a. The first coil detected is indicated by a large needle pulse.
  - b. The second, third, and fourth coils are indicated by progressively smaller needle pulses.
9. The *Coil Detect* test automatically recycles and restarts the test when the needle drops to near zero, then swings to the far right again.

## Loop Current Test

The *Loop Current* test is an important indicator of resistance problems on a line's pair. Loop current is inversely proportional to resistance. Therefore, as resistance *increases*, a pair's loop current *decreases* and as loop current *increases*, resistance *decreases*.

### Procedure

1. Turn the **MODE SWITCH** to **OFF/DIAL**.
2. Connect test leads; Black, Red, and Green to; Tip, Ring, and Ground.
3. **For Tip-to-Ring** – Turn the **MODE SWITCH** to **LOOP CURRENT** to read the current on the meter's black scale.
4. **For Tip-to-Ground** – Toggle and hold the **TIP SWITCH** in the **UP** position. Then read the meter.
5. **For Ring-to-Ground** – Toggle and hold the **RING SWITCH** in the **UP** position. Then read the meter.

**Note:** *The Ring-to-Ground current should be at least 1 ½ times the Tip-to-Ring loop current. Otherwise, there may be a ground fault at the C.O. There should be no Tip-to-Ground current.*

Loop Current: Measured in mA\*

Scale:	0 to 100 mA
Acceptable:	23 mA and higher
Marginal:	20 to 23 mA
Unacceptable:	below 20 mA

\* Per Bellcore standards. Specific company or local standards may be different.

## Power Influence Test

The *Power Influence* test specifically identifies Electro Magnetic Interference (EMI) from external sources (mainly power lines). When this test is initiated, a 600 Ohm resistance is placed across Tip and Ring which simultaneously measures Noise-to-Ground.

### Procedure

1. Turn the **MODE SWITCH** to **OFF/DIAL**.
2. Connect test leads; Black, Red, and Green to; Tip, Ring, and Ground.
3. Connect a telephone headset (buttset) to the base terminals on the Sidekick T&N.
4. Using the buttset, dial a quiet line termination. Once a connection is established, turn the **MODE SWITCH** to **PWR INFLUENCE**. The test set will hold the connection, however, the buttset will disconnect from the circuit.
5. Read the meter's black scale to determine the Power Influence levels. Each black hash mark equals 2 dBrnC.

***NOTE:** The Sidekick T&N will hold line connection when switching between Power Influence and Circuit Noise. Therefore, switching to Circuit Noise is recommended to automatically calculate line noise.*

6. Turn the **MODE SWITCH** to **OFF/DIAL** to disconnect from the line once testing is complete.

Power Influence: Measured in dBrnC\*

Scale:	0 to 100 dBrnC
Acceptable:	60 to 80 dBrnC
Marginal:	81 to 90 dBrnC
Unacceptable:	above 90 dBrnC

\* Per Bellcore standards. Specific company or local standards may be different.

## Circuit Noise Test

The *Circuit Noise* test measures the noise level across the Tip and Ring wires. Noise usually "Leaks" onto a cable pair as a result of internal pair imbalances such as; crosstalk, poor grounds, sheaths, or from external factors such as; CO equipment, subscriber equipment, Electro Magnetic Interference (EMI) or other equipment i.e.; radio transmitters, generators, transformers, etc.

## Procedure

1. Turn the **MODE SWITCH** to **OFF/DIAL**.
2. Connect test leads; Black, Red, and Green to; Tip, Ring, and Ground.
3. Connect a telephone headset (buttset) to the base terminals on the Sidekick T&N.
4. Using the buttset, dial a quiet line termination. Once a connection is established, turn the **MODE SWITCH** to **CKT. NOISE**. The test set will hold the connection, however, the buttset will disconnect from the circuit.
5. Read the meter's black scale to determine the Circuit Noise levels. Each black hash mark equals 2 dBrnC.

***NOTE:** The Sidekick T&N will hold line connection when switching between Circuit Noise and Power Influence. Therefore, switching to Power Influence is recommended to automatically calculate line balance.*

Circuit Noise: Measured in dBrnC\*

Scale: 0 to 100 dBrnC  
Acceptable: 0 to 20 dBrnC  
Marginal: 21 to 30 dBrnC  
Unacceptable: above 30 dBrnC

***NOTE:** If Power Influence is greater than 60 dBrnC, subtract Circuit Noise from Power Influence to obtain "Circuit Balance".*

\* Per Bellcore standards. Specific company or local standards may be different.

## Circuit Loss Test

The *Circuit Loss* test measures the signal attenuation on a line from the CO to the point of test. Circuit Loss is expressed in negative decibel units. The 0 dB reference for Circuit Loss is generated by the CO's 1004 Hz test signal or the multitone signal generators. If these signals are measured at their point of output, no loss is indicated (0 dB or about) on the meter. As tests are conducted further away from the test signal's output, more loss due to the increased distance the signal must travel is measured. Since circuit loss is cumulative, readings taken at the furthest test point indicate the total loss present on a pair.

## Procedure

1. Turn the **MODE SWITCH** to **OFF/DIAL**.
2. Connect test leads; Black, Red, and Green to; Tip, Ring, and Ground.
3. Connect a telephone headset (buttset) to the base terminals on the Sidekick T&N.

4. Using the buttset, dial the CO's milliwatt (1004 Hz), or a frequency generator, test number. Once a connection is established, turn the **MODE SWITCH** to **CKT. LOSS**. The test set will hold the connection, however, the buttset will disconnect from the circuit.
5. The Circuit Loss is indicated on the meter's multi-colored scale.

*Note: If the frequency generator test number sends slope, sweep, or selected frequencies, leave the test set in the **CKT. LOSS** position. Each change in frequency will produce an audible tone that registers on the meter's multicolored scale.*

6. Turn the **MODE SWITCH** to **OFF/DIAL** to disconnect from the line once testing is complete.

Circuit Loss: Measured in dB\*

Scale: +1 to -15 dB  
Acceptable: 0 to -8.5 dB (green zone)  
Marginal: -8.6 to -10.0 dB (yellow zone)  
Unacceptable: below -10.0 dB (red zone)

\* Per Bellcore standards. Specific company or local standards may be different.

## Quiz 4

1. Unacceptable Circuit Loss would measure:
  - a) 0 to -8.5dB (green zone on meter scale)
  - b) -8.6 to -10dB (yellow zone on scale)
  - c) below -10dB (red zone on meter)
  - d) none of the above
  
2. The farther away the Sidekick T&N is from the test signal's output, the less the Circuit Loss that is measured.  
T  
F
  
3. The Circuit Noise test measures the amount of noise present:
  - a) across Tip and Ring
  - b) from Tip-to-Ground
  - c) from Ring-to-Ground
  - d) from Sheath-to-Ground
  
4. An acceptable Circuit Noise level would be:
  - a) 30 to 50 dBmC
  - b) 0 to 20 dBmC
  - c) 0 to -30 dBmC
  
5. A marginal Power Influence level reading would be:
  - a) less than 60 dBmC
  - b) 60 to 80 dBmC
  - c) 80 to 90 dBmC
  - d) greater than 90 dBmC
  
6. Power Influence levels are read on the meter's black scale.  
T  
F
  
7. The Loop Current test is an important indicator of which type of problems?
  - a) resistance
  - b) signal loss
  - c) intermittent
  - d) imbalance

8. The marginal Loop Current range would be:
- a) below 20 mA
  - b) 20 – 23 mA
  - c) 23 mA and higher
  - d) None of the above
9. In the Load Coil test, a needle dip from the far right to about 50 indicates that a load coil was detected.
- T  
F
10. The maximum number of coils that the Load Coil test will detect is:
- a) 1
  - b) 2
  - c) 3
  - d) 4

## Exam 2

1. The Circuit Loss test measures the signal attenuation on a line:
  - a) from the CO to the point of test
  - b) from the customer premise to the CO
  - c) from the point of test to the customer premise
  - d) from the point of test to the fault
  
2. Since Circuit Loss is cumulative, the reading at the point of test indicates total loss on a pair.  
T  
F
  
3. Where would a marginally acceptable Circuit Loss level be read on the Sidekick T&N multicolored scale?
  - a) in the blue zone
  - b) in the red zone
  - c) in the yellow zone
  - d) in the green zone
  
4. An acceptable Circuit Noise level would read:
  - a) 0 to -30 dBmC
  - b) 0 to 20 dBmC
  - c) 20 to 30 dBmC
  - d) above 30 dBmC
  
5. Normally, a good ground or sheath on a pair acts to cancel the noise on the pair.  
T  
F
  
6. Using a telephone headset (buttset) in the Power Influence test, what is dialed?
  - a) the CO milliwatt frequency
  - b) a quiet line termination
  - c) the customer number
  - d) frequency generator test number
  
7. Once connected, the Sidekick can not be switched between the Power Influence and Circuit Noise tests until the unit is turned off.  
T  
F

8. An acceptable Loop Current test level would read:
- a) 23 to 30 mA
  - b) 60 to 80 mA
  - c) above 90 mA
  - d) below 20 mA
9. Loop current is inversely proportional to resistance, therefore as resistance increases, the loop current measured on a pair:
- a) decreases
  - b) increases
  - c) remains constant
  - d) is not affected
10. With multiple load coils in a circuit, each load coil detected gives the same amount of sweep on the meter before the test automatically recycles.
- T  
F

## Quiz & Exam Answers

Quiz 1	Quiz 2	Quiz 3	Quiz 4	Exam 1	Exam 2
1. False	1. D	1. True	1. C	1. True	1. A
2. C	2. A	2. B	2. False	2. B	2. True
3. B	3. True	3. D	3. A	3. A	3. C
4. True	4. B	4. True	4. B	4. C	4. B
5. False	5. False	5. False	5. C	5. True	5. True
6. A	6. True	6. A	6. True	6. True	6. B
7. C	7. C	7. C	7. A	7. C	7. False
8. A	8. D	8. B	8. B	8. A	8. A
9. B	9. A	9. A	9. True	9. B	9. A
10 T	10. B	10. B	10. D	10. True	10. False
				11. B	
				12. A	
				13. C	
				14. False	
				15. D	
				16. C	
				17. D	
				18. A	
				19. False	
				20. False	

# Trouble Shooting Inside Wiring

Except for wire length considerations, Inside Wire Trouble Shooting is the same as Outside Plant. Because Inside Wire lengths are much shorter, various test values will differ significantly. Successful Fault Analysis is dependent upon the following tests and meter readings.

## Testing for Good Ground

1. Connect the Green lead to Ground.
2. Connect the Tip (black) or Ring (red) lead (not both) to one side of the Inside Wiring.
3. Turn the Mode switch to STRESS TEST.
4. The Ground is good if the meter's black scale reads 40-45 or higher.

## Stressing the pair

1. With the Green and either the Tip or Ring leads still connected, connect the remaining Tip or Ring test lead.
2. With the meter still in the **STRESS TEST** Mode, determine the quality of the pair by comparing the meter reading on the black scale to the following Noise Metallic levels.

<u>Stress Test:</u>	<u>Measured in dBrnC</u>
Scale:	0 to 90 dBrnC
Acceptable:	0 to 20 dBrnC
Marginal:	20 to 25 dBrnC (test further)
Unacceptable:	25 dBrnC or higher

## Resistance Testing – Fault Isolation

1. Disconnect **ALL** the subscriber's equipment after finding a high (20+) reading.
  - a. If the Stress reading drops, the fault is in the phones.
  - b. If the Stress reading remains the same, the fault is in the Inside Wiring.
2. If the fault is in the phones, reconnect each phone (one at a time) until the phone(s) have been isolated.
3. If the fault is in the Inside Wiring, remove and *Stress* each Inside Wire (one at a time and with the phones disconnect) at the station protector until the wire(s) have been isolated.

## Resistance Testing – Toning the Fault

1. Tone the faulted Inside Wire with a Tone Generator to locate its corresponding phone jack. The fault will either be in the wire or in the jack – at the pins.
2. If the fault is in the jack, repair or replace.
3. If the fault is in the wire;
  - a. Use the 10K Resistance Scale to identify any shorts across Tip and Ring.
  - b. Alternately hold the **TIP** and **RING** switches **UP** to identify any Tip or Ring shorts to ground.

*NOTE: Before replacing any Inside Wire, check for old splices, staples, nails, nicking, loose connections, worn insulation, and any new construction.*

## Capacitance Testing – Kicking the Pair

1. If Resistance Testing failed to detect any faults, look for Opens by *Kicking* the pair.
2. While using the 10K Resistance Scale, *kick the pair* by alternately holding the **TIP** and **RING** switches **UP**, and toggling the **REV** switch. Each point on the meter's black scale represents approximately 50 ft. to the fault.

*NOTE: Opens on the Tip Wire are generally the cause of pair imbalances. Also, nominal meter movements are common because of the short length of Inside Wiring.*

3. Use a TDR to pinpoint the exact location of the fault..

**TIP:** A low range TDR (900 ft.) works best.

## CLEANING AND MAINTENANCE

To clean the Sidekick, simply wipe off any dirt or dust with a soft cloth. If necessary, lightly moisten the cloth to remove any smudges. If left inside the carry case, the Sidekick will require little care. Routine maintenance is limited to occasional battery replacement, periodic test lead cleaning, and test clip replacement.

### Ground Clip Replacement

1. **Remove the old ground clip** – Cut the green ground wire with a wire cutter or diagonal cutter approximately 1 inch behind the old clip. This ensures removal of any stressed wires close to the clip.
2. **Prepare the ground wire** – Carefully strip  $\frac{1}{2}$  inch of insulation off the end of the ground wire. If you nick the wire strands or some are still broken, cut back another inch and strip the insulation again until a *clean* section of wire is exposed.

*NOTE: Tinning or applying solder to the end of the ground wire is NOT recommended. This will lead to early failure of the wire's connection behind the ground clip.*

3. Slide the heat-shrink tubing onto the insulated portion of the ground wire.
4. Back out the ground clip screw to provide sufficient clearance for the ground wire to wrap around the shank of the screw.
5. Lay the wire between the open strain grips and bend the  $\frac{1}{2}$  inch stripped end clockwise around the ground clip's screw. The lay should place the wire's insulation against the screw's head, but **NOT** under it.
6. Tighten the screw down on the wire strands.
7. Use a crimping tool or pliers to bend the strain grips over the wire's insulation. The grips should squeeze down on the insulation firmly, but **NOT** break through the wire.
8. Slide the heat-shrink tubing over the assembled wire and ground clip end and push it snugly against the ground clip.
9. Heat the heat-shrink tubing with a heat gun until it closes down tightly over the ground clip end and evenly around the ground wire's insulation. Though not recommended, if a cigarette lighter or similar heat source is used, take care not to hold the flame too close to the heat-shrink and wire insulation as carbonization will destroy them.

**SAFETY NOTE:** Always use pliers to hold the ground clip when heating the heat-shrink tubing. The heat required to shrink this material makes the ground clip and wire insulation too hot to handle.

## Test Lead Replacement

1. Remove the battery compartment cover.
2. Using a #1 Phillips screw driver, remove the binding post set screws along with their upper flat and lock washer sets.
3. Remove the leads from the test lead channels by pulling them out through the bottom of the case.

**CAUTION: Do not remove the lower binding post flat washers. They are required to assure proper test lead connection.**

4. Strip approximately ½ inch of insulation from the replacement leads and tightly twist them in a clockwise direction.

Hint: For best results, insert and mount one test lead before mounting the next test lead.

5. Pull the test lead through the bottom of the case and loop the bare wire to match the diameter of the binding post recess.
6. Punch the test lead down and into the corresponding color marked binding post recess and channel.
7. Place the flat washer, then the lock washer on the test lead loop.
8. Insert and tighten the set screw until snug. Do not over tighten!
9. Repeat the preceding steps until the remaining test leads are replaced.

*Note: Make sure that the test lead strands are not shorted across the binding post recess or to each other.*

10. Test to verify proper installation. Then replace the battery compartment cover.

## Battery Replacement

1. Disconnect the Sidekick test leads from any external connections or pairs.
2. Turn the **MODE SWITCH** to the **OFF** position.
3. Remove the battery cover.
4. Replace all (4) batteries with known good, fresh batteries.

*NOTE: Failure to turn the unit OFF before removing the batteries can cause the unit to become inoperable. To remedy this situation, short the two battery housing connectors together for a few seconds. Then re-install the batteries.*

## FREQUENTLY ASKED QUESTIONS

What are the five most common uses for the Sidekick?

- Checking for a correct battery or unwanted battery on twisted pairs.
- Checking the longitudinal balance of twisted pairs.
- Checking for insulation leakage on twisted pairs.
- Locating faults on twisted pairs.
- Locating faults on inside wiring (IW).

**Q.** Why does the Sidekick last only a few hours after battery replacement?

**A.** Chances are you only replaced two of the four batteries. Replace **ALL FOUR** batteries.

**Q.** The Stress Test reads fine, but the pair is noisy. What should I do?

**A.** This is usually caused by a high resistance short. Remember, the Sidekick looks at a short as a balanced pair. Run the Leakage Test being sure to check not only the Tip-to-Ring, but also the Tip-to-Ground and Ring-to-Ground. Then, reverse the polarity on the Tip-to-Ring, Tip-to-Ground and Ring-to-Ground. Remember to conduct each segment of the Leakage Test for approximately 15 seconds. Then, run the Stress Test again.

**Q.** The Stress Test reads 30dBmC, but the pair works fine. Why?

**A.** Check the other working pairs in the cable. You may find that they all read about 30 dBmC. This usually indicates that this is as good as this cable will perform; so use this as your reference. Comparison readings are important. When pairs differ by more than 7 dBmC, be suspicious. When pairs differ by 10 dBmC there is definitely a problem.

**Q.** The meter needle will not move, pegs to the right or jumps to mid-scale and waves back and forth on any scale. Does my Sidekick need repairs?

**A.** Maybe. First check and replace the batteries. Ensure that the battery holder has clean, corrosion free, connection points with the cells. Also check the battery holder wires for breaks. If this fails to correct the problem, the unit will require servicing.

**Q.** The test leads are worn out. Are they replaceable?

**A.** Yes. The test leads are field replaceable. Contact your local distributor or Tempo Research for replacement.

- Q.** Can the Sidekick be used to check Hi-Cap (ISDN, T-1, DSL, etc.) service lines?
- A.** Yes. However, unlike a POTS line, high-capacity lines **MUST BE OUT OF SERVICE** before testing with a Sidekick. In most cases, Stress Test readings below 20 dBrnC should be attainable. A Stress Test reading over 20 dBrnC may indicate that the line is inducing more bit errors than desired.
- Q.** Why does the Sidekick's Stress Test identify problems that other test sets miss?
- A.** The Sidekick's Stress Test is a patented process that places both DC voltage (about 135 Vdc) and a 90 dBrnC noise signal on each wire in a pair as a reference to ground. The noise signal waves oppose each other (180°) as they travel through the pair causing them to cancel each other out. Any imbalance in the pair causes the signal level to rise; and this reading, in dBrnC, is reflected on the meter. Refer to the Operating Manual for acceptable Stress Test signal levels.
- Q.** Is the Stress Test alone sufficient to certify a pair as good?
- A.** No. Accepted practice requires running the following tests in the following order: AC volts, DC volts, Stress, Leakage, then return to Stress. If these tests read good, then the circuit is good. If you are using a Sidekick T&N, you should run the Circuit Noise, Power Influence, Loop Current, and Circuit Loss tests.
- Q.** When I run the Leakage Test, the needle jumps past midscale then drops slowly to the left. What causes the meter to act this way?
- A.** You are most likely reading into a NTID or CO circuit protector. Be sure that the CO and the customer ends are disconnected and the pair is open when running the Leakage Test. Unlike the Loop Resistance Test, the Leakage Test is looking to detect a leak in the insulation's resistance. If equipment is connected at the opposite end of the pair, the meter reads through the equipment and not the insulation. This causes the false reading.
- Q.** Is a Stress Test reading of 20 dBrnC acceptable on inside wiring?
- A.** No. Most inside wiring configurations are less than 1,000 feet. Because the Stress Test is designed for a local loop that can be miles in length, the reading for a very short run, such as in your typical residence, will be considerably less. Refer to the Inside Wiring section of your Sidekick manual for acceptable Stress Test readings.

- Q.** What is the difference between a Sidekick 7B and a Sidekick T&N?
- A.** Physically, they are the same. Electronically, the Sidekick T&N has all the same tests as the 7B plus five transmission and noise tests: Circuit Loss, Circuit Noise, Power Influence, Loop Current, and Load Coil detection.
- Q.** After running the Leakage Test for about 5 to 7 seconds, the needle started to wave back and forth between 200 and 150 on the red scale. What causes this?
- A.** Moisture. Needle movement while in the Leakage Test is caused by moisture in the cable. The voltage applied by the Leakage Test causes current to flow across the wires which creates heat. From the heat, a slight drying action occurs which raises the resistance. This causes the current flow and the heating action to stop. Then, more moisture seeps between the wires and the current flows again. This causes the heating and drying action repeat. This repetitive process can continue as long as moisture is present in the cable.
- Q.** Can I get a shock from the 135Vdc used in the Stress or Leakage Test?
- A.** You might feel a slight tingle depending upon several variables e.g.; humidity or skin moisture. With a low resistance load like yourself, the current flow is restricted to approximately 1/10,000th of an ampere; and the Sidekick can not sustain the 135 volts for more than a millisecond.
- Q.** What is the purpose of using the Reverse Switch during a Leakage Test?
- A.** The galvanic corrosion that builds up on an idle pair creates an oxide layer that can act like a diode. This diode affect can prevent the 135Vdc from passing through the corrosion when it is applied from only one side. Reversing the polarity allows the voltage to pass through the oxide layer; thus, breaking down and “Punching through” the galvanic corrosion; thereby, revealing the insulation fault. Remember to apply and to reverse the voltage for approximately 15 seconds during every segment of the Leakage Test.

# Glossary

**2400 baud rate**

Modem speed of 2400 bits per second.

**9600 baud rate**

Modem speed of 9600 bits per second.

**14.4 kpbs**

Modem speed of 14400 bits per second.

**28.8 kpbs**

Modem speed of 28800 bits per second.

**1.544 Mbps**

T-1 circuit speed of 1,544,000 bits per second.

**56 kbps**

Data transmission speed of 56000 bits per second. Your local public broadcasting company.

**64 kbps**

Data transmission speed of 64000 bits per second.

**ac or AC**

Alternating current, (ac) preferred. Is an electrical current the flows in both directions. It is what makes a phone ring.

**aerial cable**

A communications cable installed on or suspended from a pole or other overhead structure.

**alligator clip**

A clip with long narrow jaws; properly named, "Gharial clip".

**ampere**

The standard measurement unit of electrical current flow.

**amperage**

The amount of electrical current flow.

**amplification**

The process by which the output of a circuit becomes an enlarged reproduction of the input signal.

**amplifier**

A device that receives an input signal and provides as an output a magnified replica of the input waveform.

**analog video**

A video signal representing an infinite number of smooth gradations between given video levels.

**ANSI**

American National Standards Institute, a nonprofit organization that coordinates voluntary standards activities in the United States.

**ASDL**

Asymmetrical Digital Subscriber Lines - a 6 to 8 million bits per second carrier.

**audible**

The range of sound that can be heard by a normal human.

**balance**

The process of equalizing the voltage, current, or other parameter between two or more circuits or systems.

**baud**

A unit of signaling speed equal to the number of signal events per second. Baud is equivalent to bits per second in cases in which each signal event represents exactly 1 bit.

**Bellcore**

A research, development, and standards company established by the divested AT&T operating companies.

**bit**

A binary digit, either 0 or 1, that is the minimum unit of information in a binary pulse stream.

**BNC**

Bayonet Neill-Concelman is a bayonet style cable connector used extensively in TV and radio frequency equipment.

**bond**

A low resistance mechanical electrical connection.

**broadband**

A communications link having essentially uniform response over a given range of frequencies (greater than 20 kHz), that is, no perceptible degradation to the signal being transported.

**broadband Industry**

Voice, data, and/or video communications rates greater than 1.544Mbits, that is, greater than wide-band communication rates.

**Buried cable**

Cable in the ground without conduit.

**cable**

An electrically and/or optically conductive interconnecting device.

**Caller ID on Call Waiting**

A service feature that delivers calling number and/or calling name information for an incoming Call Waiting call.

**capacitance**

The property of a device or component that enables it to store energy in an electrostatic field and to release it later.

**category 5 cable**

Shielded or unshielded twisted pair that is capable of handling frequency of 100 Mhz.

**CATV**

The abbreviation for cable television.

**CO**

The abbreviation for central office.

**coaxial cable**

Commonly referred to as coax, it is a transmission line consisting of an inner conductor surrounded by an insulating material then an outer conductor; either solid or braided, the mechanical dimensions of the cable determine its impedance characteristics.

**connector block**

Also referred to as a terminal block, punch-down block, quick-connect block, and cross-connect block; it consist of insulating material supporting terminals that can be used to connect electric conductors.

**connector**

A device on the end of a wire or fiber optic cable that mates to a similar device on a specific piece, or equipment, or another cable.

**continuity**

A continuous path for the flow of current in an electric circuit.

**continuity test**

Verifies the integrity of an electrical circuit.

**converter**

A device that changes alternating current to direct current and vice versa.

**cross**

A short between two pairs, such as, bare wires touching each other. The ring wire of one pair touching the tip or ring wire of another pair.

**cross connection**

To connect cable pairs from one group to cable pairs in another group.

**cross connect box**

A terminal in which jumper wires are used to connect feeder pairs to distribution pairs.

**crosstalk**

An undesirable transfer of signals from one pair to another, usually as a result of unintentional capacitive (ac) coupling.

**CTS**

Coax tracer system. Tempo's tone and probe unit.

**dB**

Decibel. One-tenth of a bel. Measures the ratio between two powers and is commonly expressed as transmission gain, loss, or level.

**dBm**

The noise power relative to one picowatt, or -90dBm.

**dBmC**

The power in decibels relative to a noise reference of -90 dBm as measured with a noise meter and

weighted by a frequency function called "C-Message weighting".

**dc or DC**

Direct current, (dc) preferred. Electrical current that flows in one direction.

**dielectric**

An insulating material that separates the elements of various components including capacitors and transmission lines, and which an electrostatic charge is maintained.

**dial tone**

A combination of two audible tones sent from an automatic switching system to a customer to indicate that the equipment is ready to receive address signals. Typical dial tones are 350 and 440 Hz.

**dial tone voltage**

48 - 52 volts dc is the typical dial tone voltage.

**digital video**

A video signal represented by computer readable binary numbers that describe a finite set of color and luminance levels.

**distribution cable**

A cable or branch cable having terminals to which subscribers are connected from a feeder cable.

**drop cable**

A twisted pair or coaxial cable that connects a subscriber line from the terminal on the pole or surface-mounted junction box to the service entrance of a subscriber.

**duct**

A pipe or conduit installed underground or in a building.

**electrostatic induction**

The process of inducing static electric charges on a body by bringing it near other bodies that carry high electrostatic charges.

**Ethernet<sup>®</sup>**

A transmission protocol for packet switched local area networks. Ethernet is a registered trademark of the Xerox Corporation.

**F connector**

A connector used by the television industry to connect coaxial cable to equipment.

**F 81**

Used by the television industry to splice two F connectors.

**facility**

Any one of the elements of the physical telephone plant required to provide service, such as switching systems, cables, and microwave transmission systems.

**farad**

The standard unit of capacitance equal to the value of a capacitor with a potential of one volt between its plates when the charge on one plate is one coulomb and there is an equal and opposite charge on the other plate. Because a farad is a large value, it is usually expressed in micro or picofarads.

**fault**

A condition that causes a device, a component, or an element to fail to perform in the required manner, e.g., shorts, opens, etc.

**fault tolerance**

The capability of a system to continue to operate in the event of a hardware or software failure.

**feeder cable**

Cable from a CO to a cross connect box.

**frequency**

The number of complete periodic wave cycles that occur within a given length of time.

**gauge**

A measure of wire diameter. The lower the wire gauge number, the thicker the wire.

**ground**

An electrical connection to earth or to a common conductor usually connected to earth whose purpose is to protect the cables within.

**grounded**

When equipment is connected to earth or to a common connector to earth.

**HDSL**

High bit rate digital subscriber line. High speed data transmission at 1.544 Mbps.

**headend**

The master CATV distribution center from which satellite and distant broadcast systems are received, converted and transmitted as TV channels.

**high resistance open**

Wire or connection point that has deteriorated by corrosion to the point that it is almost open.

**high speed data**

Data transmissions speeds at or above 56 kbps.

**impedance**

The total passive opposition to alternating current flow.

**inductance**

An electrical characteristic, measured in henrys that opposes any changes in current flow.

**inductive amplifier**

A device that senses and amplifies line current by use of a probe.

**ISDN**

Integrated Services Digital Network. A network architecture that enables end-to-end digital connections.

**junction box**

A box where wires inside are connected to each other.

**kbps**

Kilobits per second.

**kick-meter**

A test meter's needle pulse that is caused by a sudden change in a wire's capacitive charge. Also, meter-kick.

**LAN**

Local area network. A private network that offers high-speed digital communication channels to connect computers and peripherals in a limited area.

**leakage**

A loss of energy when an electrical current travels to a path other than its intended one.

**manhole**

A utility access hole large enough to provide access to an underground

vault to install, splice, or repair cables between conduit runs.

**Mbps**

Megabits per second.

**megabit**

One million bits.

**megabyte**

One million bytes.

**megahertz**

One million hertz.

**modem**

A device that converts digital signals to and from analog signals for transmission over conventional analog telephone lines.

**nanosecond**

One-billionth of a second.

**narrowband**

A 4 kHz voice communications channel that often results in poor signal transmission.

**node**

Any network branch terminal or any terminal common to multiple branches in a network.

**null**

A minimum or zero amount.

**ohm**

The unit of measure for electrical resistance.

**open**

The break in a wire or connection.

**open (clean)**

A open pair without any other faults.

**open (dirty)**

An open pair that has another fault.

**oscillation**

A periodic change in voltage, current, or other quantity above or below a mean value.

**OTDR**

An Optical Time Domain Reflectometer is designed and used for fiber optic line testing.

**passive**

A component, device, circuit and network that is not powered.

**peak-to-peak**

The voltage difference between the most positive and the most negative peaks of an electrical waveform.

**pedestal**

The above ground enclosure used for splicing and terminating buried cable.

**PIC cable**

Polyethylene-insulated conductor cable.

**plenum cable**

A cable constructed of flame-retardant material that generates little smoke when exposed to fire.

**polarity**

The property of a physical system in which there are opposing characteristics such as negative and positive charges, or north and south pole.

**probe**

The component of an inductive amplifier that senses line current.

**pulp cable**

Early cable with paper-insulated wires. The insulation was formed directly from wood pulp.

**pulse**

A short signal duration characterized by rapid amplitude change.

**pulse TDR**

A Time Domain Reflectometer used to identify and locate breaks in a transmission line.

**pulse width**

The measured interval between the 50 percent amplitude points of the leading and trailing edges of a pulse.

**range**

The parameters of which a test or function operates within.

**readout accuracy**

A notation, such as  $\pm 2\%$ ,  $\pm 3^\circ$ , that indicates the accuracy of a measurement.

**reference noise**

A base noise level, such as 25 dB, that is used for comparing other noise levels.

**resistance**

The opposition or restriction on the flow of electricity.

**ring**

The audible signal that is produced when the CO applies ac voltage to the pair's wire.

**ring to ground**

A test procedure that determines if the ring wire is properly insulated from grounded.

**RJ11**

A (4) wire modular connector commonly used to interconnect end-user telephone equipment.

**RJ45**

An (8) wire modular connector used for Local Area Networks and some phone lines.

**RS-232**

Now, EIA/TIA 232E. An electrical and mechanical standard for digital serial information transfers between computers, computer peripherals, or communications equipment.

**short**

A very low resistance or impedance path between two or more conductors, such as, bare wires touching each other.

**signal**

An electrical or any other fluctuation or quantity that conveys an impulse for voice, data, or video messaging.

**sine**

The trigonometric function that for an acute angle is the ratio between the side opposite the angle when it is considered part of a right triangle and the hypotenuse.

**sine wave**

A wave form that represents periodic oscillations in which the amplitude of displacement at each point is proportional to the sine of the phase angle of the displacement and that is visualized as a sine curve.

**single mode optical fiber**

A step-index optical fiber with a small diameter core which has greater information capacity than multi-mode fiber.

**split**

When an input signal is distributed to several outputs.

**Spit Pair**

A splicing error between two pairs of wire where the wire on one pair is connected to the wire of the other pair.

**splitter**

A circuit or device that distributes an input signal to several outputs.

**step TDR**

A Time Domain Reflectometer that provides ultra high resolution for broadband networks.

**strand hooks**

Hooks that are attached to hand held equipment which are use to hang from stranded cable or tool belt.

**subscriber**

The end user.

**switched network**

A multi-point network that has switching capabilities.

**T1**

1.544 Mbps service.

**T2**

6.3 Mbps service.

**tag**

A number or other label identifying a cable, cable pair, or pole. A flattened brass pin on a terminal block used for wire termination by soldering or wrapping.

**talk battery**

Direct current (dc) that is supplied by the central office to the subscriber to operate the telephone set transmitter.

**tap**

A branch or intermediate circuit in a communications system.

**T-carrier**

A system whereby multiple intelligent electrical channels are modulated and transmitted over a single higher carrier wave then recovered at the receiving end by demodulation.

**telecommunication**

The transmission and reception of audio, video, data, and other intelligence by wire, radio, light, and other electronic or electromagnetic systems.

**TDR**

Time domain reflectometer. A test set used to identify and locate breaks in a transmission line.

**tip**

The rounded end of a standard telephone switch board plug which is connected to the positive side of the battery from the CO.

**tip to ground**

A test that identifies a shorted tip wire to either earth and/or the ground from the CO battery.

**token ring**

The use of a token to control access in a token-ring network.

**tone**

A single-frequency audio signal usually used as a reference.

**tone generator**

A device that produces a tone.

**topology**

Describes how different facilities and services interact.

**transmission**

The transfer of electric power, signals, or intelligence from one location to another wire, fiber optic, or radio means.

**transmission level**

The power (in dBm) measured from a reference point.

**wire center**

A local terminating point for telephone wires, switches, and devices.

**wire, line**

Copper, copper steel, copper-aluminum or steel wire strung between poles and used for telephone carriers.